



NOTES:

1. MATERIAL IS HALOGEN FREE PLASTIC,HIGH TEMP. UL 94V-0 , COLOR: WHITE OR BLACK
2. SPEC. PLS. REFER TO PS-50429-XXXXX-XXX
3. TERMINAL P/N:50430-TXXX
4. PART NUMBER

50486-XXX H X X X-XXX

NO OF CKTS ———— 001:NORMAL
 POLARIZATION ———— COLOR
 0: NONE 0: WHITE
 1: BLACK
 MATERIAL
 H: NYLON 66

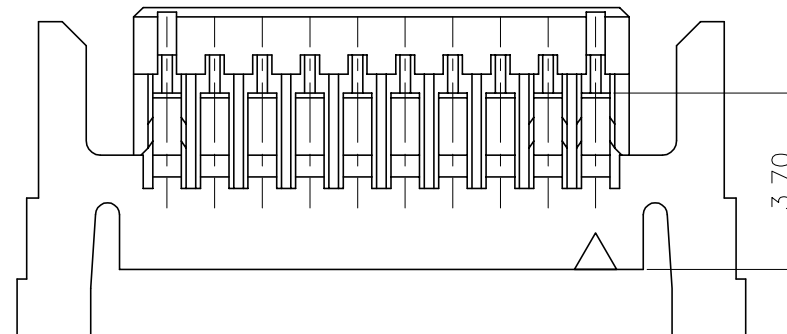
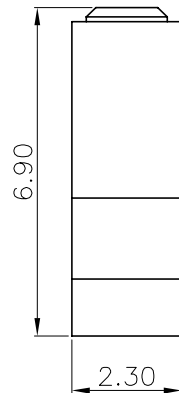
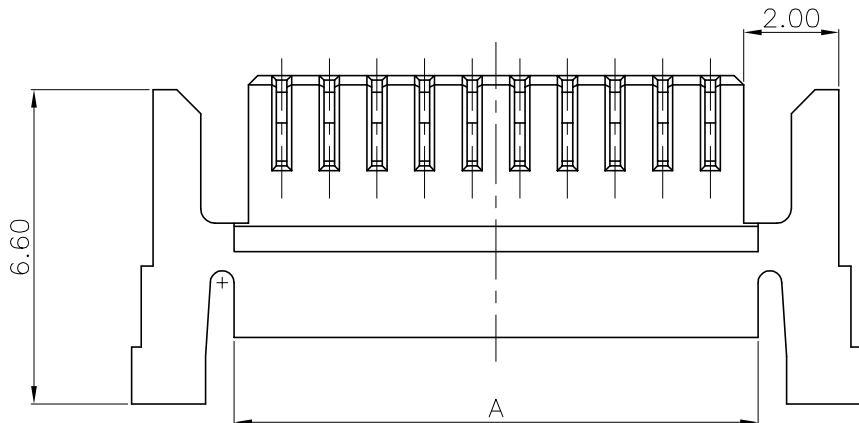
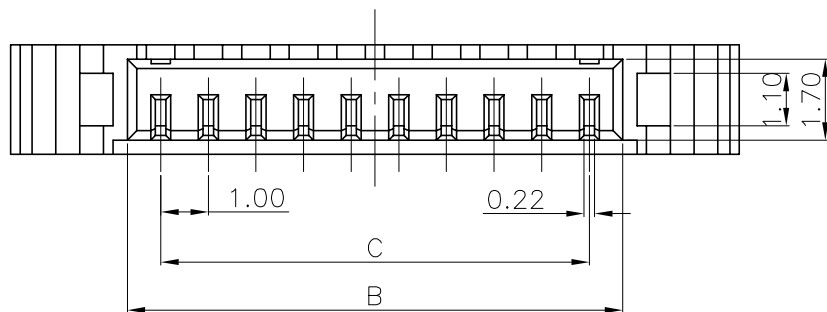

CKTS	A	B	C
006	7.00	6.40	5.00
008	9.00	8.40	7.00
010	11.00	10.40	9.00
012	13.00	12.40	11.00
014	15.00	14.40	13.00

QUALITY SYMBOLS MAJOR Ⓜ CRITICAL Ⓢ GENERAL TOLERANCES (UNLESS SPECIFIED) X. ±0.5 .X ±0.25 .XX ±0.15 .XXX ±0.1 ANGLES ±2°	DRAWN BY YUIAHAO	DATE 23/06/06	
	CHECKED BY XUZHUYONG	DATE 23/06/06	
	UNITS mm		SIZE A4
	SCALE 1:1	SHEET NO. 1 OF 1	RFG NO. N/A
			DWG NO. 50486-XXXHXXX-XXX